

13 On Lexical Structure and Syntactic Projection

1 INTRODUCTION

A central assumption in generative grammar research on the relationship between syntax and the lexicon is that syntax is a projection of the lexicon. The structure of sentences is a reflection of the lexical properties of the individual lexical items they contain. In the standard view, each lexical item is associated with a lexical entry that contains three kinds of information, as indicated in (1):

- (1) The contents of a lexical entry:
 - a. Morpho-phonological information
 - b. Semantic information
 - c. Morpho-syntactic information:
 - syntactic category
 - subcategorization
 - theta grid (argument array, theta-roles, linkings)

In classical theories of lexical structure, the morpho-syntactic component of a lexical entry consisted of a specification of c-selection (or subcategorization) and a theta grid, specifying a given lexical item's argument array, the thematic roles of its arguments, and the way these theta-roles are linked to the arguments. The lexical entries of *fang* 'put' and *zhidao* 'know' looked like (2) and (3):

- (2) *fang* 'put':
 - a. [+V, -N]
 - b. [+ ___ NP PP]
 - c. (x, y, z)
 - d. (Agent, Theme, Location)
- (3) *zhidao* 'know':
 - a. [+V, -N]
 - b. [+ ___ NP/CP]
 - c. (x, y)
 - d. (Perceiver, Theme)

In recent years, it has been shown that a lexical entry of this kind suffers from a problem of overspecification, as there is considerable redundancy among the kinds of information provided. It has been observed by Pesetsky (1982), for example, that information about subcategorization (c-selection) is largely predictable from its meaning, which includes s-selection, or the specification of participants of a predicate, in terms of their ontological types. If a verb s-selects a thing, then it c-selects an NP, as in (2). If a verb s-selects a proposition, then it c-selects an NP or CP. Information about c-selection can be predicted by a principle of Canonical Structural Relation (CSR) from information about s-selection.

There are a few cases where c-selection cannot be fully predicted from s-selection, the best known concerning the difference between *ask* and *wonder* in English, first studied by Grimshaw (1979). Both verbs s-select a proposition, but only *ask* c-selects an NP. A similar point can be made with the difference between *zhidao* ‘know’ and *renwei* ‘think.’ Both of these verbs s-select propositions, but whereas a proposition can be expressed in a concealed way as an NP in the case of *zhidao*, this is not possible with *renwei*.

- (4) a. Zhangsan zhidao [Lisi tou-le ta-de shu].
Zhangsan know Lisi steal-PERF his book
‘Zhangsan knows that Lisi stole his books.’
- b. Zhangsan zhidao zhe-jian shi.
Zhangsan knows this-CL matter
‘Zhangsan knows (about) this matter.’
- (5) a. Zhangsan renwei [Lisi tou-le ta-de shu].
Zhangsan think Lisi steal-PERF his book
‘Zhangsan thinks that Lisi stole his book.’
- b. *Zhangsan renwei zhe-jian shi.
Zhangsan thinks this-CL thing
‘*Zhangsan thinks this thing.’

Pesetsky (1982) proposed that such differences can be captured in a more meaningful way by whether or not a given verb is lexically specified to be capable of assigning (Accusative) Case.¹ A similar distinction can be made between verbs like *reside* and *inhabit*, both s-selecting a Location but each having a distinct structural realization of it.²

It has also been observed in the literature (Grimshaw 1990 and references cited there) that information about thematic roles, in particular the role labels, need not be specified in the theta grid (or argument structure) of a given lexical item. The fact that the three arguments of *fang* ‘put’ are Agent, Theme, and Location may be derived from the meaning of the

verb, and therefore need not be specified again in the argument structure. What is needed is merely the information that *fang* is a three-place predicate, one that takes three arguments, or has three places in its argument structure:

- (6) *fang* 'put'
{x, y, z}

The meaning of the verb should predict that these three arguments bear the thematic roles of Agent, Theme, and Location. Given the Projection Principle of Chomsky (1981), all these arguments (with their theta-role information) are projected to the syntactic component. It is further assumed that argument positions in the lexical structure are projected to specific positions in syntax according to the Thematic Hierarchy (cf. Grimshaw 1990; Larson 1988; etc.):

- (7) The Thematic Hierarchy
Agent > Experiencer > Goal > Theme > . . . > Obliques

So that the argument that bears the thematic role of Agent will appear in the highest argument position of a sentence at D-Structure, the argument that bears Theme will appear in a lower position, and the Location argument will appear even lower.

One version of the theory of syntactic projection takes the argument structure of a lexical item to consist of a flat list of argument places, and the Thematic Hierarchy ensures that these argument places are projected to appropriate positions in the syntactic structure. A more sophisticated theory of argument structure now takes it that the argument structure itself is structured in accordance with the Thematic Hierarchy, and that the D-Structure of a sentence is simply a direct projection of the hierarchically structured argument structure of its verb. This is achieved by the theory of syntactic projection, the strong version of which is Baker's (1987) Uniformity of Theta Assignment Hypothesis (UTAH):

- (8) Uniformity of Theta Assignment Hypothesis (UTAH)
Identical thematic relationships between items are represented by identical structural relationships between those items at the level of D-Structure.

Assuming that argument structures are structured according to the Thematic Hierarchy, one question that arises is (9):

- (9) Why the Thematic Hierarchy? Why is it as stated in (7) or something like (7)?

A plausible answer to this question lies in the idea that the meanings of lexical items are themselves highly structured and highly constrained. Up to now, we have only mentioned that the lexical entry of a verb must include its meaning. Some “paraphrase” of the lexical item must be given. There is good reason to suppose that the content and form of the “paraphrases” are highly structured. In particular, the meaning of a verb may be decomposed into one or a small number of “pure verb meanings” that it shares with a large number of other verbs, plus other idiosyncratic features that distinguish it from the other verbs. And these component meanings of a verb are structured in a highly constrained manner. The use of lexical decomposition allows certain generalizations to be made across large numbers of lexical verbs of similar semantic types. And the ways these component meanings are structured are also of considerable generality so as to express significant generalizations about the nature of the lexicon and lexical semantics. I refer to the idea, of course, that *kill* is decomposed into [CAUSE [BECOME [DEAD]]] in its underlying representation, as was first proposed by McCawley (1968) and in similar treatments employed by other generative semanticists, and more recently by Dowty and other categorial grammarians. A recent GB approach employing the idea of lexical decomposition is found in Larson (1988) and related work. The idea of treating lexical semantics in compositional terms has also been pursued in a number of recent works by Jackendoff (1990, and the references cited there). Jackendoff proposes that the meaning components are organized in a Lexical Conceptual Structure (LCS), in which they serve as functions mapping semantic types to semantic types. For example, the LCS of *run* and *drink* are respectively given in (10) and (11):

(10) *run*
 $[_{\text{Event}} \text{ GO } [_{\text{Thing}}], [_{\text{Path}}]]$

(11) *drink*
 $[_{\text{Event}} \text{ CAUSE } ([_{\text{Thing}}]_i; [_{\text{Event}} \text{ GO } ([_{\text{Thing}} \text{ LIQUID}]_j; [_{\text{Path}} \text{ TO } ([_{\text{Place}} \text{ IN } ([_{\text{Thing}} \text{ MOUTH OF } ([_{\text{Thing}}]_i)])))])))]]$

In Hale and Keyser (1990), lexical decomposition is employed in constructing the “Lexical Relational Structure” (LRS) of a lexical item. The LRS may be thought of as an abstraction of the LCS, containing that part of the LCS that is syntactically relevant. Like Jackendoff’s LCS, the argument structure (the LRS) of a verb does not just consist of a list of argument positions {x, y, z} that are hierarchically ordered as stipulated by the Thematic Hierarchy. These argument positions are actually placed in a “lexical syntactic structure” defined by the verb’s LCS. Thus, the full argument structure of *put* is the LRS that follows:³

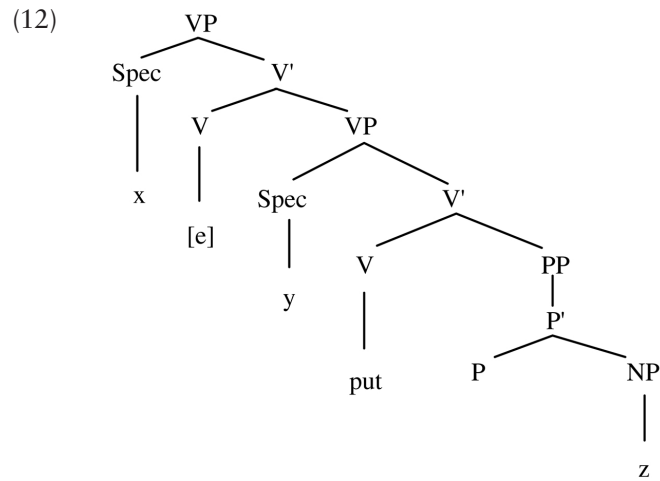

In (12), the empty verb, by virtue of taking a VP complement that denotes an event of occurring, has the “pure meaning” of CAUSE. The argument *x*, by virtue of being the Spec of a causative verb, has the theta-role of Agent (or Causer). The argument *y*, by virtue of being the Spec of the lower VP, a category denoting an occurring (an inchoative or unaccusative construction), has the role Theme; and the argument *z*, by virtue of being in the complement position of an unaccusative category, is Location. The theta-role labels of the arguments are thus defined by this structure.

The LRS thus represents a kind of “event structure.” An assumption incorporated in such event structures is that in a composite event involving two or more eventualities (a causing, an action, a becoming, or a state), the causing event is more prominent than (i.e., asymmetrically c-commands) the becoming event, which is in turn more prominent than the state. From here the Thematic Hierarchy follows: Agent is higher than Theme because the eventualities denoted by CAUSE or DO are higher than the eventualities denoted by BECOME and BE. There is also an answer to the question why there are so few theta-roles. This simply arises from the fact that verbs are decomposable into a very small set of “pure verbs.” The small number of eventualities explains the small number of possible theta-roles in natural language.

Hale and Keyser propose that the LRSs also define and constrain how certain lexical items may come to be derived in the lexicon. A denominal verb like *shelve* may be derived via Move α applied in “l-syntax” (lexical syntax) to an LRS akin to something like *put x on a shelf* in “s-syntax” (syntactic syntax):

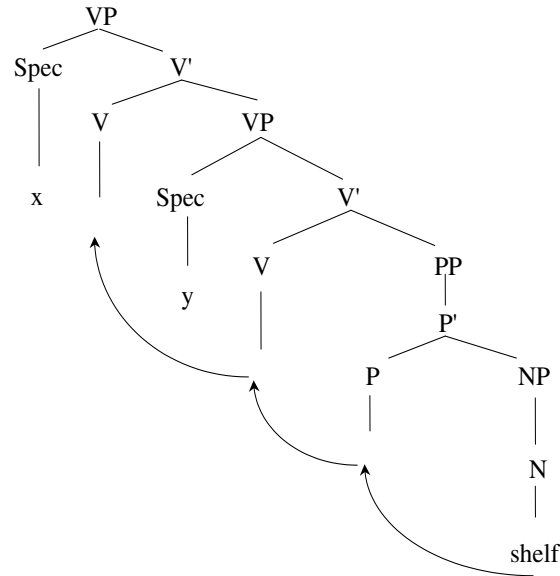
(13) Derivation of *shelve* in LRS:

Unergative verbs like *foal*, *laugh*, *jump*, etc., are treated as denominal verbs, from LRSs that are not unlike the syntactic structures of *had a foal*, *had a laugh*, *did a jump*, etc.

In other words, certain verbs have an event structure in the lexicon in which they are embedded under an abstract “pure verb” of some kind. Although Hale and Keyser are concerned primarily with only causatives and certain denominal verbs, it may be that all verb types may be represented in a similar way, as complements to some abstract verb. Under this hypothesis, all activity verbs (including unergatives and transitives) are complements to a predicate akin to DO. Inchoative predicates are embedded under BECOME or OCCUR. Statives are embedded under BE or HOLD. Causatives, of course, are embedded under CAUSE (in addition to DO). (Here CAUSE, DO, etc., are to be distinguished from *cause*, *do*, etc.)

- (14) a. *ku* ‘cry’:
[x DO [x ku]]
- b. *kan shu* ‘read books’:
[x DO [x kan shu]]
- c. *pang* ‘become fat’:
[OCCUR/COME ABOUT [x pang]]

- d. *pang* ‘fat’
[BE/HOLD [x pang]]
- e. *xihuan* ‘like’
[BE/HOLD [x xihuan y]]
- f. *qi-si* ‘to anger someone to death’
[x DO [x CAUSE [COME ABOUT [y qi-si]]]]

Under this view, each verb has an event structure associated with it in which it is embedded as the complement of some eventuality predicate. Such eventuality predicates are sometimes called aspectual predicates (Dowty 1979).

We assume that the eventuality predicates may be phonetically ECs. General principles of grammar require that such empty categories be lexically supported (or licensed) by S-Structure. Thus, the verb of the mostly deeply embedded complement must be raised to the position occupied by an eventuality predicate. Hale and Keyser assume that LRSs like those in (14) may trigger Move α (in particular, head-movement) in the lexicon, by which the lexical category in the most deeply embedded complement moves up to combine with one or more eventuality predicates, deriving various lexical verbs. A possibility remains that such structures as those in (14) may be directly projected to D-Structure and that head-movement operates as a normal syntactic process, in the mapping between D- and S-Structure. In such cases, we expect to find evidence for the postulation of these event structures at the syntactic level.

In what follows I will show that there is evidence from Chinese that the event structures of the kind postulated in (14) are in fact observable in the syntax. That is, there is syntactic evidence for such event structures at S-Structure, and therefore that a theory of lexical structure based on lexical decomposition not only provides a plausible answer to the question arising from the existence of the Thematic Hierarchy and the small number of theta-roles, but receives considerable support from its ability to explain interesting phenomena falling in the domain of syntax.

2 LEXICAL DECOMPOSITION AND D-STRUCTURE IN CHINESE

Syntactic evidence for the event structures comes from constructions in which the verb appears away from its “expected” position, in a position outside of its maximal VP. In such constructions the verb can be seen to have raised into a position occupied by an abstract eventuality predicate. In Huang (1994) I showed that this can be observed in four kinds of constructions:

- (15) a. Causative constructions
 b. Possessive object constructions
 c. Constructions involving event quantification
 d. Genitive agent constructions

Causative constructions that involve syntactic verb raising are illustrated in (16):

- (16) a. *nei-jian shi ji-dong-de Zhangsan liu-chu-le yanlei.*
 that-CL matter excited-DE Zhangsan came-to tears
 ‘That matter got Zhangsan so excited that he came to tears.’
 b. *nei-ping jiu zhui-de Zhangsan zhan-bu-qi-lai.*
 that-bottle wine drunk-DE Zhangsan cannot-stand-up
 ‘That bottle of wine got Zhangsan so drunk that he could not stand up.’

I have argued elsewhere that in these constructions, the causative verb originates in a “double-decker” VP structure under an abstract predicate CAUSE in D-Structure, as in:

- (17) *nei-jian shi* [_{VP} CAUSE [_{VP} Zhangsan *jidong-de liu-chu-le yanlei*]].
 that-CL matter Zhangsan excited-DE came-to tears

The surface form is obtained when the verb raises to take up the position of the abstract predicate CAUSE. This is treated as a case of syntactic causativization, rather than lexical causativization, because verbs like *jidong* ‘excited’ and *zhui* ‘drunk’ cannot themselves be used causatively taking a causee argument as its complement. This property makes them different from causative verbs like *break*, *excite* in English, which could be derived in the lexicon through a lexical operation applying at the level of LRS. The causative meaning is available only in the presence of an additional resultative predicate (like ‘came to tears,’ ‘could not stand up,’ etc.). This V-result combination clearly exceeds the size of a lexical category and cannot be the result of lexical derivation, so it must be treated syntactically.

Verb movement in the Possessive Object Construction is illustrated in examples like those in (18). The underlying structure for such a sentence involves a “double-decker VP shell” of the sort proposed by Larson (1988). I claim that the upper verb is a non-causative, action predicate that may be symbolized by DO, as in (19):

- (18) a. *tamen bang-le wo-de piao.*
 they tie-PERF my ticket
 ‘They kidnapped me.’

- b. qing ni bie kai Lisi de wanxiao.
 please you don't make Lisi 's fun
 'Please do not joke with Lisi.'

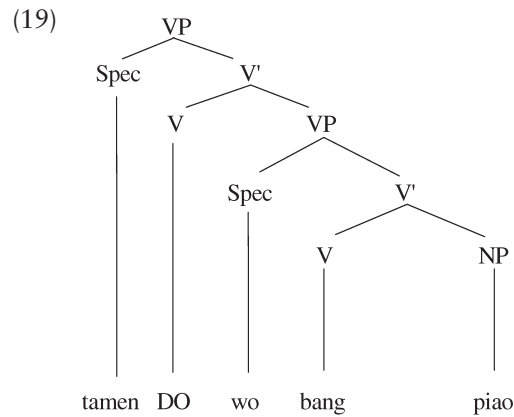

Certain sentences involving event quantification provide strong evidence for the existence of an abstract eventuality predicate DO:

- (20) a. ta kan-le san tian (de) shu.
 he read-PERF three day ('s) book
 'He read (books) for three days.'
- b. ta chang-le liang ci (de) ge.
 he sing-PERF two time ('s) song
 'He sang twice.'

The sentences in (20) contain expressions of duration and frequency that are, semantically speaking, quantifications over events expressed by the verb phrases (or the entire sentences), but syntactically these expressions clearly occur in construction with a concrete, non-event-denoting noun, each forming a constituent with the latter, as can be shown by standard constituency tests. In Huang (1994), I argued that this apparent syntax-semantics mismatch in fact does not exist, if sentences like (20) are analyzed as having each been derived from a structure of gerundive nominalization whose verbal head has moved out of the gerund VP, into the position of the higher eventuality predicate DO, as shown in (21):

(21)

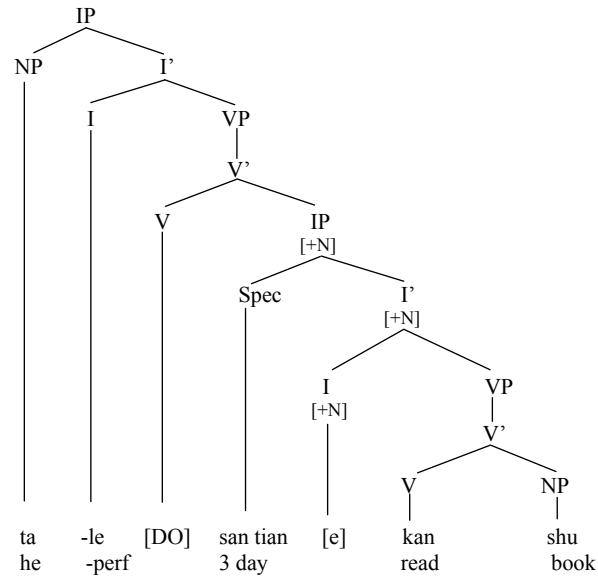

In this structure, the quantity expression *san tian* ‘three days’ modifies the gerund meaning ‘reading book.’ Thus this D-Structure is analogous in form to the English sentence “He did three days of book reading.” After the verb *kan* moves to the empty verb position, the sentence comes to have the surface form “He read three days of books.”

Gerundive nominalization under DO is also involved in sentences like the following:

- (22) a. ta nian ta-de shu, wo shui wo-de jiao.
 he read his book I sleep my sleep
 Lit. ‘He read his book and I slept my sleep.’
- b. ni haohao jiao ni-de Yingwen ba.
 you well teach your English PRT
 Lit. ‘You better teach your English well.’
- c. ni chang ni de ba
 you sing you ’s PRT
 Lit. ‘You sing yours.’
 ‘You go on with your singing.’

According to my proposed analysis, (22b) would be derived from the underlying structure (23):

- (23) ni haohao [_{VP} DO [_{VP} ni-de jiao Yingwen] ba.
 you well your teach English PRT

I have illustrated one construction involving an abstract predicate CAUSE and three constructions involving an abstract action verb DO. I want to point out now that in fact the existence of underlying eventuality predicates is more widespread than meets the eye. In the case of action sentences with DO, sentences like the following also provide important support for our analysis. For more details, see Huang (1994).

- (24) ta (de) laoshi dang de hao.
he ('s) teacher serves DE well
'He serves well as a teacher.'
- (25) zhe-ge xin, ni haishi bie dan.
this-CL heart you better not carry
'It's better that you don't do this worry.'
- (26) a. ta qi-lei-le ma le.
he ride-tired-ASP horse le.
(i) he went horseback riding and got tired.
(ii) he rode a/the horse tired.
b. ta qi-lei-le liang-pi ma.
he ride-tired-ASP two-CL horse.
'He rode two horses tired.'
c. ta qi-lei-le liang-ci ma.
he ride-tired-ASP two-time horse
'He got tired twice from going horseback riding.'

Each of these sentences has to do with the existence of a determiner of a concrete noun, which nevertheless quantifies an event semantically. Examples of this sort lead us to realize that the phenomena are widespread, and by no means limited to a few lexical items. Indeed, since our proposed analysis does not depend on the existence of event-quantifying expressions, it is entirely reasonable to assume that the same general analysis also applies to eventive sentences that do not contain expressions of event quantification.

The examples we have given to motivate the underlying predicate DO are primarily those that denote activities, in Vendler's classification. Those that exhibit the properties of underlying CAUSE primarily involve accomplishment predicates. In fact, accomplishment predicates can be analyzed as being embedded under both DO and CAUSE, because in accomplishments there is typically an activity that causes a new event to occur or a new state to come about. Like activity sentences, accomplishment sentences also allow event quantifiers occurring in construction with an object NP:⁴

- (27) Zhangsan gan-zou-le liang ci Lisi.
Zhangsan chase-away-ASP two times Lisi
'Zhangsan chased away Lisi twice.'

What about predicates that denote achievements and states? Some achievement verbs are unergative or transitive, and it might be possible to postulate the predicate DO, for sentences like (28) and (29):

- (28) Zhangsan ying-le liang ci qiu.
Zhangsan win-ASP two times ball
'Zhangsan won twice in ball games.'
- (29) Zhangsan chenggong-le liang ci.
Zhangsan succeed-ASP two times
'Zhangsan succeeded twice.'

Other achievement verbs are unaccusative, however, and clearly cannot be analyzed in the same way. Note that even unaccusatives exhibit event quantification within NP:

- (30) pao-le liang ci fanren le.
escape-ASP two times prisoner ASP
'Twice, prisoners have run away.'
- (31) zheli diu-le san ci shu.
here lose-ASP three times books
'Three times, books got lost from here.'
- (32) waimian gua-qi-le liang ci feng.
outside blow-ASP two times wind
'Twice it started to blow outside.'

Rather, the underlying predicate is the one-place predicate BECOME or OCCUR. This predicate is itself unaccusative, so that the D-Structure of (30) looks like (33):

- (33) OCCUR [liang ci [pao fanren]]
two times escape prisoner

The fact that the frequency expression can occur between the verb and the internal argument in these sentences again shows that the verb has raised, and this is evidence that there is a higher predicate position, marked by OCCUR in this case, to which the verb must raise.

Other inchoative sentences may be similarly represented, with stative predicates embedded under OCCUR (or BECOME).

- (34) Zhangsan pang-le liang bang.
Zhangsan fat-ASP two pounds
'Zhangsan gained weight by two pounds.'

- (35) taiyang de liang hong-qilai le.
 sun 's face red-INC ASP
 'The sun's face reddened.'

Summarizing, we have seen that the predicates of all event sentences may be analyzed as being embedded under a pure event predicate of some sort at D-Structure. The most interesting syntactic evidence for this analysis comes from sentences in which the verb has moved out of its "expected" position and landed at a higher position outside of the maximal VP. By contrast, there is no similar "overt" evidence for a stative predicate moving out of its maximal projection into a higher pure predicate position:

- (36) Zhangsan hen congming.
 Zhangsan very clever
 'Zhangsan is clever.'
- (37) wo xihuan shuxue, bu xihuan Yingwen.
 I like math not like English
 'I like mathematics, but do not like English.'

Stative sentences like (36) and (37) do not exhibit the phenomena of event quantification or enter into the genitive agent construction:

- (38) *wo xihuan-le san ci de shuxue.
 I like-ASP 3 times 's mathematics
 'I liked mathematics three times.'
- (39) *wo xihuan wo-de shuxue.
 I like my mathematics
 Lit: 'I do my "liking mathematics".'
- (40) *ta de shuxue hen xihuan.
 he 's math very like

 cf. ta de shuxue jiao de hen hao.
 he 's math teach DE very well

The lack of evidence for verb raising in these cases may lead one to the plausible conclusion that statives, unlike eventives, do not have an underlying eventuality predicate. On the other hand, one might assume that the ungrammaticality of (38)–(40) has an independent explanation. For example, the fact that statives do not take event-denoting quantifiers simply follows from the fact that they denote states, and that states cannot be quantified by frequencies or durations, whence (38) is ungrammatical. If the ungrammaticality of (39) and (40) can be likewise attributed to independent factors, then the possibility still remains that statives are embedded

under a higher eventuality predicate of an appropriate sort, perhaps the predicate BE or HOLD (see Parsons 1991).

3 ON THE NATURE OF THE EVENTUALITY PREDICATES

We have seen that sentences in Chinese exhibit interesting *prima facie* evidence for lexical decomposition, in that a simple verb may be represented by a combination of two or more verbal positions. In particular, each verb may involve an underlying verb like CAUSE, DO, BECOME, OCCUR, BE, or HOLD. The existence of these phonetically empty verbs triggers verb movement, explaining observed surface word order patterns. The idea that verbs move out of their local maximal VP into a higher verbal position has been around for a long time already in the generative literature. More recently, Larson (1988) argues that all transitive verbs originate in a position lower than the theme object and move into a higher “VP shell” at S-Structure. Bowers (1993) proposes that the phrase structure of a sentence includes a projection of Predicate Phrase, which takes a VP as its complement and an external argument as its subject. A similar proposal is made in Tang (1990) for Chinese clause structure. Johnson (1992) argues that all verbs move out of their maximal VP into the head of a higher projection whose identity he did not discuss. One question that this inevitably raises is whether this higher V position has any content, or is just a pure formal entity posited to accommodate the theory of head-movement. A natural answer to this is that the head of the VP shell or the Predicate Phrase is occupied by one of these eventuality predicates, which identifies its complement as an action, a becoming, an occurring, a situation, or a complex event of causation. That is, the postulation of the eventuality predicates provides semantic content to the higher syntactic positions postulated in the recent literature.

This idea of decomposition is, of course, essentially that of the generative semanticists. Although one version of the idea was shown to be difficult to maintain, there are alternative versions that are free from the difficulties raised. For example, in “Three reasons for not deriving *kill* from *cause to die*,” Fodor (1970) observed the following contrast in grammaticality:

- (41) John caused the man to die on Sunday by shooting him on Saturday.
 (42) *John killed the man on Sunday by shooting him on Saturday.

Furthermore, although the sentence (43) is ambiguous, with the *by* phrase modifying either *cause* or *die*, the sentence (44) is not ambiguous at all:

- (43) John caused Bill to die by swallowing his tongue.
 (44) John killed Bill by swallowing his tongue.

The answer to these problems is that the decomposition analysis does not literally derive the structure underlying (42) or (44) from the structure underlying (41) and (43) respectively. Examples (41) and (43) each involve a structure of sentential complementation at the syntactic level, with two full verbs each of which has its own maximal projection and its own argument structure. In the lexical decomposition analysis of *kill* as indicated in (45), there are several possible ways to explain the differences between *kill* and (the lowercase) *cause to die*. First, we may assume that incorporation takes place in the lexicon in an LRS of *kill* like (45) and that *kill* is directly inserted into a simple verb position at D-Structure.

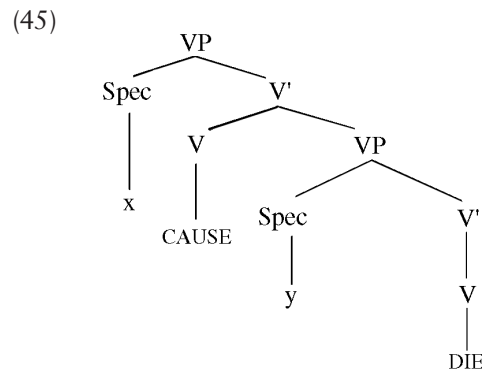

Since LRSs are only concerned with positions in a core argument structure, adverbial modifiers are not represented in (45). Rather, the adverbials are generated in appropriate positions at D-Structure, licensed by some appropriate heads (cf. Travis 1988; Tang 1990). Since there is only one verb at D-Structure, no more than one time phrase or *by* phrase is allowed.

The same result can be obtained even if syntactic head-movement is posited. The needed assumption is that as a result of incorporation, the argument structures of the two verbs must merge into one. More specifically, the argument structure of the lower verb is absorbed into the argument structure of the higher verb. In case the number of argument positions available in the composite argument structure is less than the sum of argument positions selected by the two verbs, some arguments must be left out, or be “theta-identified” with others in the sense of Higginbotham (1985). See Li (1990) and subsequent work by him for a detailed study of theta-identification involving V-V compounds. An extension of a similar mechanism to adjuncts would ensure that, in V-movement structures, any time or manner adjunct, for example, associated with the lower verb must be identified with that associated with the higher verb.

Another way to express this idea is to say that V-movement chains constitute a single “extended projection” of the lower verb in the sense that it

adds an argument place to the argument structure of the lower verb, but does not select any adjuncts or modifiers of its own. In Chomsky (1992), argument positions associated with a single head-chain are equidistant to a given position. That is, the capitalized CAUSE is different from the lower-case *cause* in that, unlike the latter, it only exists as part of a complex predicate and serves only to extend the argument structure of the lower verb.⁵ In this respect, it behaves like *do* and *occur*, which exhibit the phenomenon of “transfer” even contexts in which they appear as full main predicates. Reichenbach observed that modifiers of *occur* may transfer to the event that it is predicated of. The four sentences in (46) are equivalent.

- (46) a. A flight occurred over the North Pole in a light aircraft in 1926.
 b. A flight over the North Pole occurred in a light aircraft in 1926.
 c. A flight over the North Pole in a light aircraft occurred in 1926.
 d. A flight over the North Pole in a light aircraft in 1926 occurred.

The same observation can be made of *do* in (47):

- (47) a. John did yesterday’s reading of the poem.
 b. John did the reading of the poem yesterday.
 c. John read the poem yesterday.

These constructions are reminiscent of the “light verb construction” in Japanese discussed by Grimshaw and Mester (1988), Miyagawa (1989), Terada (1990), Kajihara (1992), and others. Japanese uses a large number of “verbal-noun” expressions either of Chinese origin or of Sino-Japanese origin. In Chinese these expressions are often used as verbs, but in Japanese they must occur with the verb *suru* in one of two forms. They can occur as nominals, with the Accusative Case marker, as the object of *suru*. Or they may occur in uninflected form directly preceding *suru*.

- (48) a. benkyoo-o suru benkyoo suru ‘to study’
 b. kaisetsu-o suru kaisetsu suru ‘to explain’
 c. keikoku-o suru keikoku suru ‘to warn’
 d. cyuumon-o suru cyuumon suru ‘to order’

The “o-suru” construction occurs with sentences with an external argument, i.e., transitive action sentences or unergatives:

- (49) a. Hanako-wa sensei-ni shitumon-o shi-ta.
 Hanako-TOP teacher-DAT question-ACC suru-PAST
 ‘Hanako questioned the teacher.’
 b. Hanako-wa [oba-no uchi]-e denwa-o shi-ta.
 Hanako-TOP Aunt’s house-to telephone-ACC suru-PAST
 ‘Hanako telephoned Aunt’s house.’

- (50) a. Taroo-ga seki-o shi-ta.
 Taroo-NOM cough-ACC suru- PAST
 ‘Taroo coughed.’
 b. Taroo-ga kusyami-o shi-ta.
 Taroo-NOM sneeze-ACC suru- PAST
 ‘Taroo sneezed.’

With event-denoting unaccusatives and stative sentences, however, the form “o-suru” is unacceptable:

- (51) a. *atarashii riron-ga tanzoo-o shi-ta.
 new theory-NOM birth-ACC suru-PAST
 ‘A new theory is born.’
 b. *Tanaka sensei-ga shikyo-o shi-ta.
 Tanaka teacher-NOM death-ACC suru-PAST
 ‘Professor Tanaka died.’
 (52) a. *tomo-ga kimi-no kansha-o shi-teiru.
 friend-NOM you-GEN appreciation-ACC suru-PRESPROG
 ‘The friend is very appreciative of your efforts.’
 b. *kono NP-wa ano PP-no c-command-o shi-teiru.
 this NP-TOP that PP-GEN c-command-ACC suru-PRESPROG
 ‘This NP c-commands that PP.’

On the other hand, the construction in which *suru* is directly preceded by the uninflected “verbal noun” is acceptable regardless of verb classes. Thus, all of (51)–(52) become grammatical once the Accusative case is deleted, and so are those in (49)–(50):

- (53) a. Hanako-wa sensei-ni shitumon shi-ta.
 Hanako-TOP teacher-DAT question suru-PAST
 ‘Hanako questioned the teacher.’
 b. Hanako-wa [oba-no uchi]-e denwa shi-ta.
 Hanako-TOP Aunt’s house-to telephone suru-PAST
 ‘Hanako telephoned Aunt’s house.’
 (54) a. Taroo-ga seki shi-ta.
 Taroo-NOM cough suru-PAST
 ‘Taroo coughed.’
 b. Taroo-ga kusyami shi-ta.
 Taroo-NOM sneeze suru-PAST
 ‘Taroo sneezed.’

364 *Between Syntax and Semantics*

- (55) a. atarashii riron-ga tanzoo shi-ta.
 new theory-NOM birth suru-PAST
 ‘A new theory is born.’
 b. Tanaka sensei-ga shikyo shi-ta.
 Tanaka teacher-NOM death suru-PAST
 ‘Professor Tanaka died.’
- (56) a. tomo-ga kimi-ni kansha shi-teiru.
 friend-NOM you-DAT appreciation suru-PRESPROG
 ‘The friend is very appreciative of you.’
 b. kono NP-wa ano PP-o c-command shi-teiru.
 this NP-TOP that PP-ACC c-command suru-PRESPROG
 ‘This NP c-commands that PP.’

This array of properties seems to suggest that there are two uses of the verb *suru*. In the “o-suru” construction, *suru* is a two-place predicate akin to the transitive verb *do* in English, which s-selects an agentive or otherwise animate being as its subject and an action as its complement. In addition, it c-selects an NP (as a realization of the action it s-selects) and assigns Case to the NP. Alternatively, it contains [+Case], and hence c-selects an NP, cf. Pesetsky (1982). In this case *suru* behaves like the empty DO that we posited in connection with sentences involving event-quantifying measure phrases and the possessive agent construction in Chinese. The difference is that verb raising has occurred in Chinese, but it has not in Japanese. That is, the *o*-marked complements of *suru* are gerundive constructions, i.e., nominalized verb phrases, which denote actions. Only *suru* with these selectional properties can assign the Accusative Case. Where an unaccusative or stative VP is embedded under it, *suru* (with the meaning of ‘occur’ or ‘be’ rather than ‘do’) is a one-place predicate that has no external argument and does not assign Case. Hence unaccusative or stative VPs cannot occur in the “o-suru” construction. (This analysis is at variance with Grimshaw and Mester, who argue that the *suru* does not have an argument structure of its own. See Terada (1990) and Kajihara (1992) for alternatives to their analysis.)

The other use of *suru*, the one without the Accusative marker, seems to be an overt form of a general eventuality predicate DO, OCCUR, or BE. In this case *suru* s-selects an eventuality (an action, an event, or a state) as its complement, and c-selects a VP as the structural realization of the complement. In other words, in each case we have a Larsonian VP shell with *suru* occupying the higher V position. If *suru* selects an activity, it also selects an agent as its subject, like the verb *do*. If it selects a non-active event (an occurring), or a state, then it does not select a subject, like the raising verbs *occur* and *be*. Since VPs do not need Case, the “verbal noun” need not be marked with the Accusative case. Instead

of nominalization, here we have incorporation, by which the lower verb moves up to form a complex predicate with *suru*. Since *suru* selects an eventuality (which can be an action, an event, or a state), all verb types are compatible with this use of *suru*.

Thus the so-called light verb *suru* may be simply regarded as the Japanese counterpart of the empty “eventuality predicate” we have posited. It has been proposed (Grimshaw and Mester 1988; Miyagawa 1989) that the light verb construction involves a phenomenon of argument transfer. We can understand these to be the result of complex predicate formation. When the eventuality predicate combines with the main predicate of its complement, arguments of the individual predicates become arguments of the composite predicate, or are theta-identified with the latter.

Summarizing, there is evidence for a lexical decomposition approach to lexical semantics. In Chinese the evidence exists in the form of an empty verbal position to which a verb may raise. Similar evidence has been adduced in English in treatments of double-object constructions (Larson 1988), of object positions (Johnson 1992), and of other aspects of clausal structure (e.g., Bowers 1993). In Japanese, evidence comes from the light verb construction in which the main predicates are embedded under a semantically bleached verb.

4 LEXICAL DECOMPOSITION AND “EVENT TALKS”

If the lexical decomposition approach to lexical semantics is on the right track, it provides important support for the semantic theory that has been developed in one form or another since the important work of Donald Davidson (1967). Davidson’s classical observation is that the logical form of action sentences, but not that of stative sentences, contains an underlying position expressing the existence of an event. Thus, although a simple sentence like (57) appears to contain only a verb and two definite, non-quantificational arguments, a proper representation of its logical form indicates that it involves existential quantification.

- (57) Zhangsan da-le Lisi.
Zhangsan hit Lisi.

The logical form of (57) is not the simple (58), but something along the lines of (59a)–(59c):

- (58) hit (Zhangsan, Lisi)
- (59) a. $(\exists x)$ (Zhangsan hit Lisi (x))
b. $(\exists x)$ (hit (Zhangsan, Lisi, x))
c. $(\exists e)$ (hitting (e) & Subject (e, Zhangsan) & Object (e, Lisi))

Example (59a) is the logical form provided by Reichenbach (1947), according to which the entire sentence is predicated on the event. Davidson takes the event to be an argument of the predicate *hit*, as is shown in (59b). Parsons (1991) takes the event as being defined by the verb itself. Following Davidson's semantics, Higginbotham (1985) proposes that the argument structure of each event predicate contains an "event place":

(60) hit (x, y, e)

In fact, Higginbotham and Parsons have extended Davidson's theory to sentences of all eventuality types, so that even a stative predicate has a place for a state or situation.

While the Davidsonian semantics is undoubtedly accepted now by many as a central part of mainstream semantic theory, the question has always remained as to how the semantics is to be related to its syntax, in particular, where the event argument can be located within a standard theory of syntactic structure. It is a standard assumption that an argument in syntactic structure corresponds to a variable position in logical form, and conversely. In (60), the variables *x* and *y* correspond to the syntactic constituents *Zhangsan* and *Lisi*, but the event variable appears to correspond to no position in syntax.

One answer to this question that has been proposed is that the event place really does not denote an event per se, but refers to a temporal/spatial location. Davidson himself has observed that an event entails a location and a time, so if John hit Bill, then he hit him at some place and some time. Thus, the variable *e* in (60) might be considered to represent an implicit argument denoting time and place. This answer is not entirely satisfactory, however. For one thing, if the Davidsonian argument is taken to literally denote a temporal/spatial location, then there should be two event places, since time and place are expressed in syntax by two separate constituents. Furthermore, a time/place constituent is generally considered an adjunct but not an argument in syntax, and they behave on a par with other adjuncts, with respect to extraction, theta-marking, optionality, etc. In addition, this interpretation by itself does not account for some of the facts that have been shown to motivate the Davidsonian argument. Consider an argument for the event place, given by Parsons (1991), based on inference patterns like the following:

(61) In every burning, oxygen is consumed.

(62) Agatha burned the wood.

(63) Oxygen was consumed.

The inference from (61) to (63) is clearly valid, even though there is no reference to an event in the second premise. Adding a time or location argument

in (62) will lead to existential quantification over temporal/spatial locations, but still does not refer to an event. However, if an underlying event argument is assumed in the argument structure of *burn* in (62), it would be existentially quantified and the inference goes through in standard predicate calculus. Similarly, the assumption of an event place aptly ensures that although (64) entails (65) and (66), the combination of (65) and (66) does not entail (64):

(64) John saw Bill at the bank yesterday.

(65) John saw Bill at the bank.

(66) John saw Bill yesterday.

That (65) and (66) do not jointly entail (64) is not expected if none of these sentences involve existential quantification. But if all these sentences involve existential quantification over events, then the failure of entailment simply follows from the fact that (65) and (66) are bound by independent existential quantifiers.

(67) $(\exists e)$ (saw (John, Bill, e) & at the bank (e) & yesterday (e))

(68) $(\exists e)$ (saw (John, Bill, e) & at the bank (e))

(69) $(\exists e)$ (saw (John, Bill, e) & yesterday (e))

That is, (65) says that there is an event that took place at the bank, and (66) that there is an event that took place yesterday. But the combination of (65) and (66) may well refer to two separate events of seeing, one at the bank last week, and one yesterday in the market. There need not be an event of seeing that took place at the bank yesterday.

If the event place denotes an event per se, rather than a temporal/spatial location, then we are back to the same question: what position does this event place occupy in syntactic structure?

The lexical decomposition analysis provides a ready answer. In Japanese, the event argument directly appears as the complement of the light verb *suru*, in both versions of the light verb construction. In Chinese, the event argument is the complement of the empty eventuality predicate DO, CAUSE, OCCUR, or BE. Assuming as I have that the eventuality predicates occupy syntactic positions at D-Structure, then events and states are simply the internal arguments of these predicates. Instead of the logical forms in (59), the logical form of (57) is (70) (assuming restrictive quantification):

(70) $(\exists x)$ (hitting Lisi (x)) (Zhangsan DO x))

Given the verb-raising analysis we gave to it, the sentence (71):

- (71) ta xue-le liang ci Yingwen.
 he study-PERF twice English
 ‘He took up English twice.’

has the logical form (72):

- (72) $((2x (xue\ Yingwen\ (x)) (ta\ DO\ x))$

A sentence like (73) is ambiguous:

- (73) ta mai-le san-ben shu.
 he buy-PERF three books

On the one hand, there is an event in which he bought three books; on the other, there are three books each of which involves an event of buying. In the former reading, there is a single event, and in the latter, there can be a maximum of three separate events. This ambiguity is akin to the ambiguity we find with sentences like (74)–(75):

- (74) Someone from two areas of social science was nominated for membership in the Academy.
 (75) Someone bought every book.

In (74), either someone whose research crosses two areas of social science got nominated (one single nominee), or in each of two areas of social sciences someone got nominated (maximally two nominees). In (75), either one single person bought all the books, or every book was bought by someone or another (maximally ten buyers for ten books). The ambiguity of (73) can be treated as one that arises from the interaction of two quantifiers: a quantification of the books by *san ben* and an existential quantification over the event. Under one reading, ‘three books’ has scope internal to the event argument, and under the other reading, it is “inversely linked” (May 1977) to the event argument. The LF representations, after QR has applied, are given in (76):

- (76) $((\exists x: x=shu) (Ey: y=mai\ x) (ta\ DO\ y))$ (Inversely linked)
 (77) $((\exists y: y = ((\exists x: x=shu)(mai\ x)) (ta\ DO\ y))$ (Internal scope)

Summarizing, in the cases we have seen, the hypothesis that there is an abstract “light verb” above an event-denoting predicate provides a syntactic root for the semantics of events. Although we have seen that this level of

representation can be syntactic (e.g., D-Structure), as we have assumed is the case in Japanese and Chinese, it is possible that for some constructions in some languages, this underlying representation exists in the lexicon but not in syntax. That is, as has been suggested by Hale and Keyser for English, it is possible that the event structure exists only in the form of an argument structure, or LRS, which may be thought of as an abstraction of the syntactically relevant parts of Jackendoff's LCS. Thus, in Hale and Keyser's terms, verb movement takes place in the lexicon, forming a denominal verb like *laugh* from the LRS (78):

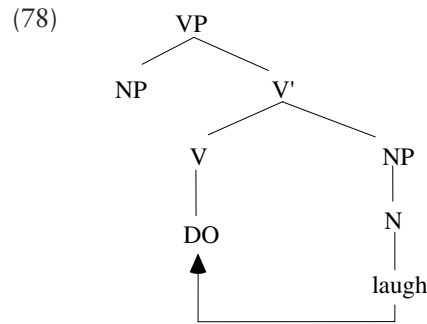

As a result of this lexical operation, the event argument NP is erased, and the verb is used as an intransitive unergative, having the resulting argument structure (79), which is then projected into syntactic structure as a one-place predicate:

(79) laugh (x)

There are two possible ways to talk about the semantics of events in terms of its syntax even if verb movement is considered a lexical process. One possibility is that semantic interpretation has direct access to lexical structure in addition to syntactic structure. The “L-syntax” (the LRS) may directly provide input to semantic interpretation, where an event is represented as a constituent. Another possibility is that, although the event argument in (78) is suppressed as a result of a lexical operation, it is not entirely deleted, but continues to exist as an “implicit argument” in the sense of Roeper (1984). In some cases the implicit argument does appear, e.g., as a cognate object, in (80):

(80) John laughed a laugh.

As Keyser and Roeper (1984) show, implicit arguments exist in passives but not ergatives:

(81) The boat was sunk to collect insurance.

- (82) *The boat sank to collect insurance.

The difference between passives and ergatives is that passives involve suppressed agents but ergatives do not. If it can be assumed that arguments that are suppressed by a lexical operation continue to exist as an implicit argument, then instead of (78) the argument structure (83) is projected to syntax, and the semantics of an event can be directly read off from its syntax:

- (83) laugh (x, e)

5 CONCLUSION

As a conclusion, I note a few aspects of semantics that have been discussed in Eventish terms and consider their relation with the underlying event-argument hypothesis. It has been observed (most recently by Krifka 1990) that sentences like the following exhibit semantic properties that are not directly readable off from their syntax given standard rules of composition:

- (84) a. 4,000 ships passed through the lock last year.
b. More than 10,000 people travel on USAir each month.
c. I have already washed 200 dishes today.

A related group of sentences, which have been treated in some detail by Leder (1991), exhibit similar properties:

- (85) a. The occasional sailor who comes in will be shot.
b. You can see an occasional cloud in the sky.
c. An occasional woman in America speaks Finnish.
d. Let's go have a quick cup of coffee.

In the sentences in (84) a numeral quantifier associated with a concrete noun can be interpreted as referring not to the number of ships, people, or dishes, but to the number of ship-passing, traveling, or dish-washing events, so that (84a) can be true even if only twenty-five hundred ships actually participated in the passing, as long as some of them pass through the lock more than once to make a total of four thousand passing events. In the sentences in (85), a nominal modifier appears to denote the properties of an event verb below it (as in (85a)) or above it (as in the others), rather than the properties of the head noun. Thus, (85a) does not talk about a sailor who is occasionally a sailor, but one who comes in occasionally. Examples (85b–c) mean, respectively, that occasionally you can find a cloud in the sky or an American woman speaking Finnish.

These cases thus present a kind of syntax-semantics mismatch that are reminiscent of the cases of event quantification in Chinese we discussed earlier. A reasonable question that arises is whether these cases can be treated in the same way that we have proposed, as involving movement out of an event argument into a higher predicate position of the type represented by DO, OCCUR, etc.

While it is not difficult to devise our syntax in such a way that these sentences can be treated in terms of an abstract light verb construction, a number of facts suggest that they should be treated differently. For one thing, the phenomenon illustrated in (85) is not observed at all in Chinese, even though the cases of event quantification involving frequency and duration quantifiers are widespread; *ouran de* ‘occasional(ly)’ in Chinese must be directly interpreted with the head noun or verb that it occurs in construction with:

- (86) a. wo pengshang-le yi-chang ouran-de yu.
I meet-PERF one-CL occasional rain.
‘I encountered an occasional rain.’
- b. women pengjian-le yi-ge ouran-de guoke.
we meet-PERF one-CL occasional passer-by
‘We met an occasional passer-by.’
- c. women ouran (de) kanjian yi-ge nüren.
we occasionally see-PERF one-CL woman
‘We occasionally saw a woman.’
- d. *women kanjian-le yi-ge ouran-de nüren.
we see-PERF one-CL occasional woman.

Secondly, the phenomenon illustrated in (85) is extremely limited, subject to lexical idiosyncrasies. Thus although one can use (85c) to mean “occasionally a woman can be found speaking Finnish,” one cannot use (87):

- (87) *A frequent woman in Europe speaks more than two languages.

to mean “Frequently, a woman in Europe can be found speaking more than two languages.” This lack of generality suggests a lexical treatment. Perhaps for the adjectival *occasional*, one may simply list the reading “occasionally observed,” or “a small quantity/number of” (an occasional woman = a few instances of a woman).⁶

The cases illustrated in (84) are likewise subject to limitations that make them difficult to analyze in general syntactic terms. Examples like (84) are acceptable only when the speaker has reason (or excuse) to be vague about the actual number of ships, people, etc., and as such they are probably better dealt with as cases of vagueness, rather than ambiguity. For example, if one knows well that a single person has entered the room two hundred

times, it is simply a lie to say that two hundred people entered the room today. Such a sentence may be accommodated if at least, say, 120 different people were involved. On the other hand, it is possible to say that you have washed two hundred dishes if you are to be paid by the number of washed dishes, even if the same single dish has been washed two hundred times. It seems that in these cases the quantified nouns are being interpreted as different instances of objects at different stages of time. That is, a dish washed today is a different dish from the dish that is made dirty tomorrow. (Cf. *John is not himself today.*) This interpretation is subject to certain pragmatic constraints, and should not be derived syntactically by a general process of verb movement.

One more important case that has been cited in support of an underlying Davidsonian argument has to do with the interpretation of bare plurals in English, studied in depth by Carlson (1977). Carlson observed that bare plurals in English exhibit variable interpretations depending on the kinds of predicates with which they are associated. With “stage-level predicates,” which describe events or some transient properties of their subjects, a bare plural receives an existential interpretation, whereas with an “individual-level predicate,” which ascribes a general property to its subject, a bare plural is interpreted generically. The point can be illustrated with bare NPs in Chinese also:

- (88) a. Zhangsan zai gen xuesheng tanhua.
Zhangsan at with student talk
'Zhangsan is talking with students.'
- b. yuyanxuejia you zai chaonao le.
linguists again at quarrel ASP
'Linguists are quarreling again.'
- c. lang lai-le!
wolf come-PERF
'Wolves are coming!'
- (89) a. Zhangsan hen xihuan yonggong de xuesheng.
Zhangsan very like diligent student
'Zhangsan likes diligent students.'
- b. yuyanxuejia bu dong kexue.
linguists not understand science
'Linguists don't understand science.'
- c. lang pao-de kuai.
wolf run fast
'Wolves run fast.'

To account for bare plurals uniformly without ad hoc devices like empty determiners, Carlson proposed that bare plurals should be treated as names

of kinds. Stage-level predicates are assumed to involve existential quantification of some temporal/spatial slices (called “stages”) that realize the kinds, but individual-level predicates do not. Thus the logical forms of the sentences in (88) are:

- (90) a. $(\exists s)$ (R (xuesheng, s) & (gen-tanhua (Zhangsan, xuesheng, s)
 b. $(\exists s)$ (R (yuyanxuejia, s) & chaonao (yuyanxuejia, s)
 c. $(\exists s)$ (R (lang, s) & lai-le (lang, s)

Example (90b), for example, says that some slices of the professional linguistics community are involved in a quarrel. This is equivalent to saying that some linguists are having a quarrel. The existential readings of (88a) and (88c) are also represented in (90). Individual-level predicates, however, do not invoke stages, so bare plurals are interpreted generically, referring to whole kinds. Example (89a) means that Zhangsan likes the kind of things we call diligent students. Example (89b) says that the kind of things we call linguists do not know science, etc.

In Carlson’s theory, the logical form of stage-level sentences thus includes a position denoting stages. Recently, Kratzer (1989) and Diesing (1989) propose to interpret this position in LF as being filled by the Davidsonian argument, interpreting it as denoting not an event, but a temporal/spatial location. Kratzer further assumes that the temporal/spatial argument is the external argument of the stage-level predicates. Following Williams’s theory of syntactic projection, all external arguments are mapped into [Spec, IP] at D-Structure, and all other arguments are mapped into VP. Thus, in the case of stage-level predicates, since the Davidsonian argument is already mapped to Spec of IP, the subject argument is mapped to Spec of VP. The Spec of VP may in turn raise to Spec of IP, presumably due to de-thematization of the latter, which places the Time/Place argument in an adjunct position. The resulting S-Structure of a stage-level sentence will have its subject in Spec of IP binding a trace in Spec of VP, as in (91). In the case of an individual-level predicate, however, the subject is the external argument already, and it must be base-generated at Spec of IP at D-Structure, and does not bind a trace in VP in the S-Structure, as in (92):

- (91) $[_{IP}$ yuyanxuejia $[_{I'} [_{VP}$ t_i you $[_{V'}$ zai chaojia]]]]
 linguists again at quarrel

- (92) $[_{IP}$ yuyanxuejia $[_{I'}$ bu $[_{VP}$ $[_{V'}$ dong kexue]]]]
 linguists not understand science

Assuming the framework of unselective binding proposed by Heim (1982), Kratzer and Diesing treat bare plurals as indefinites that do not have inherent quantificational force but derive their quantification from their local binder. Adapting Heim’s proposal, all material in Spec of IP is mapped

into the restrictive clause of a logical form, where the subject is bound by a generic “adverb of quantification” (Lewis 1975); whereas all material in VP is mapped onto the nuclear clause, where a plural will be bound by “existential closure.” Since the subject of an individual-level predicate appears only in Spec of IP, it is bound in the restrictive clause by the Generic operator, and receives a generic interpretation. In the case of a stage-level predicate, however, the subject may be lowered down to VP (under QR or reconstruction), where it can be bound by existential closure, thus giving rise to its existential interpretation.

While this theory succeeds in deriving some aspects of the semantics of bare plurals, one crucial aspect of the Kratzer–Diesing account is that they take the stage–individual distinction to represent a parameter between two predicate types with respect to the VP Internal Subject Hypothesis: only stage-level predicates have VP-internal subjects, individual-level predicates do not. As pointed out in Burton and Grimshaw (1992), this makes the powerful prediction that VP coordination can occur only when the conjuncts are uniformly stage-level predicates or uniformly individual-level predicates. A coordinate VP containing a stage-level predicate in one conjunct and an individual-level predicate in another is ruled out by the CSC.

(93) John liked Bill a lot but often criticized him.

Another problem the Kratzer–Diesing hypothesis encounters has to do with VP-fronting and the interpretation of anaphors. Huang (1993) discusses the following contrasts between predicate fronting and argument fronting:

- (94) a. Which pictures of each other do they think we should buy?
 b. Criticize each other, they said we should not.
- (95) a. Which pictures of each other did they say that I should buy?
 b. *How proud of each other did they say that I should be?

The contrasts between the (a) and (b) sentences indicate that, in a fronting structure, although the anaphor *each other* can be bound by either the matrix or the embedded subject when the fronted phrase is an NP, the ambiguity does not arise if a predicate is fronted. In the latter case the anaphor must be bound by the lowest subject as if no movement had taken place. It is suggested in Huang (1993) that this follows straightforwardly from the VP Internal Subject Hypothesis, because under this hypothesis a predicate (but not an NP) will contain a trace of the lowest subject, and that this trace will necessarily be the antecedent of the anaphor, as required by Condition A of Binding Theory. When fronting takes place the internal subject trace will be moved along with it, and no other binding possibility for the anaphor will arise. The S-Structure of (94b), for example, is:

- (96) [_{VP} t_i Criticize each other], they said we_i should not [_{VP} e].

In this structure, *each other* is necessarily bound by t_i, which is the trace of *we*. Therefore *each other* must take *we* as its antecedent. In the case of (94a), the fronted NP does not contain a trace of *we*, so *each other* may have different antecedents depending on where the moved phrase is reconstructed to.

Under this account, the Kratzer–Diesing hypothesis predicts that only when a stage-level predicate is fronted will an anaphor contained in it be required to be bound by the lowest embedded subject. Ambiguity may arise if an individual-level predicate is fronted. This prediction is, again, incorrect, as can be seen by comparing (94a), with a stage-level predicate *criticize* fronted, and (95b), with an individual-level predicate *proud* fronted. In both cases *each other* must be bound by the lower subject. The following sentences, with the individual-level predicate *resemble*, illustrate the same point:

- (97) a. . . . and resemble each other, they said we surely do.
 b. * . . . and resemble each other, they said I surely do.

A third problem with the Kratzer–Diesing hypothesis is that it predicts that all bare plurals contained in VPs should be existential. As Diesing herself notes, sentences with experiencer verbs like *hate*, *love*, *respect*, *like*, etc., take generic plurals:

- (98) a. I love dogs.
 b. They respect diligent scholars.

But generic object plurals are much more widespread:

- (99) a. Lions resemble cats.
 b. They discussed human beings.
 c. John learned about mammals yesterday.
 d. Bill talked a lot about books last Friday.

These problems, taken together, cast doubt on the Kratzer–Diesing hypothesis. Although the hypothesis, derived from Carlson, seems to be correct that only stage-level predicates are associated with a Temporal/Spatial “argument,” that fact does not seem to bear on the position of a subject within a clause. Perhaps, as suggested by Chierchia (1992), the stage–individual difference is that whereas stage-level predicates select an existential adverb of quantification (Lewis 1975) like *sometimes*, *at some time*, *somewhere*, individual-level predicates select a generic operator (e.g., *generally*). And a bare plural acquires its quantificational force from the adverb of quantification that binds it. This would already go a long way

towards the semantics of plurals, though sentences like (99b–d) will need further explanation.

Finally, note that the stage–individual distinction of predicates should be distinguished from the difference between events and states. Although event predicates are generally (perhaps always) stage-level predicates, not all stage-level predicates denote events. Adjectives, for example, denote states, but many adjectives are by definition stage-level predicates: *sick*, *available*, *excited*, *angry*, *ready*, etc. Thus it seems that the so-called Davidsonian argument should be considered to denote an event (or an eventuality) in the literal sense, and not a temporal/spatial location.